

Advanced Stroke Controller



Where Innovation Flows



The Neptune Advanced Stroke Controller allows the capacity of any Neptune 500 Series, 600 Series or 6000 Series Hydraulic Metering Pumps to be automatically controlled in response to a standard 4-20 mA DC process signal with incremental contact closures as alternate. The one-piece controller-positioner mounts directly to the pump. No machining or any special drillings or tappings needed to retrofit pump.

Ideal for water/wastewater, power and process industry applications, anywhere that pump flow must be automatically proportioned or varied.

FEATURES/BENEFITS

- Four button LCD user interface
- Permanently lubricated, maintenance free
- Unrestricted duty cycle
- Input signal adjustments:
 - Zero and span settings unlimited
 - Adjustable dead band
 - Adjustable upper and lower limits
- Signal interruption "memory." If process signal is lost, unit can remain in its last position or move to a preset position
- Multiple units can be wired in series or parallel
- Alarm function monitors: 1) movement to max/min preset limits; 2) movement to adjustable upper/lower limits. Gives early warning to malfunctions or process upsets, allows for quick corrective actions
- Manual operation if power or signal is lost
- Stroke position indicator on controller. Permits fast, easy visual check of pump stroke length
- Separate signal and power entrance connections to terminal blocks

SPECIFICATIONS

- NEMA 4 (IP65) or Explosion-Proof (Class I, Division 1, Groups C & D; dust & ignition-proof rated Class II, Division 1, Groups E, F & G)
- FM (CSA) and CE available
- Power supply: single phase 120/240 VAC (switch selectable), 50/60 Hertz
- Operating temperature: -4°F to 150°F*
- Input signal: 4-20 mA DC or 0-5 VDC or 0-10 VDC switch selectable. Also accepts incremental contact closures (dry contacts).
- Output: isolated 4-20 mA DC; loop-powered, up to 800 OHM load at 24V
- Precise pump stroke positioning accurate to $\pm 0.2\%$

ELECTRIC STROKE CONTROL FOR SERIES 500/600/6000 PUMPS

Controller-Positioner fits all Series 500 Series Pumps:

AC5000 (NEMA 4 / IP67 Enclosure)

*NOTE: Can be mounted on only one head of a duplex pump.

Controller-Positioner fits all Series 600 Series Pumps:

AC6000 (NEMA 4 / IP67 enclosure)

Controller-Positioner fits all Series 6000 Series Pumps:

AC6100 (NEMA 4 / IP67 enclosure)

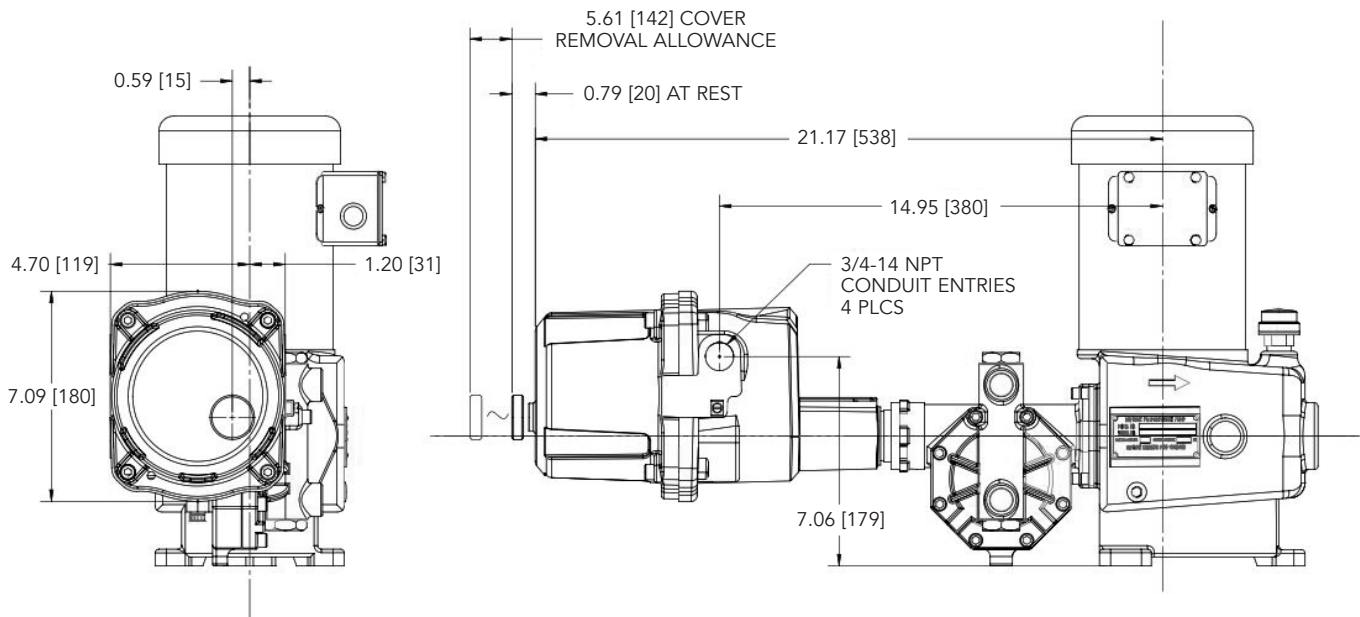

Neptune Metering Pump with Advanced Stroke Controller

NPT-10130-F-01

Copyright 2022 PSG®, a Dover company

Authorized PSG® Partner:

Where Innovation Flows 



PSG
22069 Van Buren Street
Grand Terrace, CA 92313-5651 USA
P: +1 (909) 422-1700 • F: +1 (909) 783-3440
psgdover.com/neptune