



# INSTALLATION OPERATION & MAINTENANCE



## NEPTUNE Glycol Feed System GE-50-1



NEP-ZL128163

PSG  
22069 Van Buren Street  
Grand Terrace, CA 92313 USA  
P: +1 (215) 699-8700 F: +1 (215) 699-0370  
neptune1.com

Copyright 2018 PSG®, a Dover Company

NEP-ZL128163  
03.2018\_REV 1



## WARNING

### Please read thoroughly before installation, operation or maintenance of any Neptune pump

#### **EQUIPMENT MISUSE HAZARD**

Equipment misuse can cause the equipment to rupture, malfunction and result in serious injury.

- This equipment is for professional use only.
- Read all instruction manuals, tags, and labels before operating the equipment.
- Use the equipment only for its intended use.
- Do not alter or modify this equipment.
- Be certain all operators of this equipment have been trained for safe working practices, understand its limitations, and wear safety goggles and or equipment when required.
- Do not exceed the maximum working pressure of the system as mentioned on the pump tag.
- Do not use the pump head or the suction or discharge piping to pull the equipment.
- Do not move pressurized pump.
- Use fluids or cleaning agents for cleaning that are compatible with the pump parts. Read the fluid and cleaning agent manufactures warnings and also refer to the material compatibility chart
- Comply with all applicable local, state and national safety regulations.
- Do not allow pump to run dry for a long periods of time.

#### **PRESSURIZED EQUIPMENT HAZARD**

Spray from leaks or ruptured components can splash fluid in the eyes or on the skin and cause serious injury.

- Shut off the pump and depressurize before performing any maintenance.
- Do not tamper with or perform unspecified alteration of this device.
- Use only pipe, hose, and hose fittings rated for maximum rated pressure of the pump or the pressure at which the pressure relief valve is set at.
- Always wear protective clothing, face shield, safety glasses and gloves when working on or near your metering pump.
- Additional precautions should be taken depending on the solution being pumped. Refer to MSDS precautions from your solution supplier.
- Do not stop or deflect fluid leaks with your hand, body, glove, or rag.
- Tighten all fluid connections before operating the equipment.
- Replace worn, damaged, or loose parts immediately.
- Before performing any maintenance requiring pump head and or valve (wetted parts) disassembly, be sure to relieve pressure from the piping system and where hazardous process chemicals are present.
- Make the pump safe to handle for the personal and the environment by cleaning and chemically neutralizing the pump as appropriate.
- Wear protective clothing and use proper tools as appropriate to avoid any injury.
- If the diaphragm has failed, process chemical may have contaminated the pump hydraulic oil. Handle with appropriate care. Clean the pump and replace oil as necessary. Discard the contaminated oil as per the local code.
- If the diaphragm fails in a double diaphragm pump, pressurized process chemical can be present in the Neptune leak detection vacuum system. Take proper care to clean and handle them.

#### **FIRE AND EXPLOSION HAZARD**

Improper grounding, poor air ventilation, open flames, or sparks can cause a hazardous condition and result in fire or explosion and serious injury.

- Ground the equipment. See motor installation instruction for grounding procedure.
- Do not pump non recommended flammable or explosive fluids.
- Static electricity may generate by fluid moving through pipes and hoses. A static spark could be produced by high fluid flow rate. Earthing of the pump is a must.
- Provide fresh air ventilation to avoid the possible buildup of flammable fumes from the process chemicals.
- Keep the pump area free of debris, including cleaning agent, rags, and any flammable material.
- Follow the cleaning agent and other cleaning recommendations as mentioned in the operation and instruction manuals.
- Use cleaning agent with the highest possible flash point to clean the pump parts if needed.
- If there is any static sparking while using the equipment, stop operation at once. Identify and correct the problem before starting up the pump.

#### **TOXIC FLUID HAZARD**

Hazardous fluids or toxic fumes can cause serious injury or death if splashed in eyes or on the skin, swallowed, or inhaled.

- Know the specific hazards of the fluid you are using. Read the fluid manufactures warnings.
- Store hazardous fluid in an approved container. Dispose of hazardous fluid according to all local, state and national guidelines.
- Wear the appropriate protective clothing, gloves, eyewear and respirator.
- Pipe and dispose of the exhaust air safely. If diaphragm fails, the fluid may be exhausted along with the air in mechanical diaphragm pump. Also oil vapor may breathe out of the air breather installed on the gear box.

#### **SOUND HAZARD**

The sound pressure level of the pump may exceed 80dBA in some of the pumps.

- Observe all safety precautions when operating the pump within close proximity for extended periods by wearing hearing protectors.
- Extended exposure to elevated sound levels will result in permanent loss of hearing acuteness, tinnitus, tiredness, stress, and other effects such as loss of balance and awareness.

#### **MECHANICAL HAZARD**

The pump may shake or vibrate during operation.

### General Description

Neptune Chemical Pump Company's Glycol Feed System "GE-50-1" is intended for the automated addition of glycol into a closed chilled and hot water systems. The Glycol Feed System automatically maintains pressure in the loop by adding glycol solution to make up losses.

Glycol addition is controlled by a pressure switch with adjustable high and low set points. When the pressure in the loop reaches the low set point, the pump begins to feed glycol into the system until the high set point is achieved and stop the pump.

### Installation Instructions

**WARNING:** "Risk of electrical shock" The Glycol Feed System pump is supplied with a grounding type plug. To reduce the risk of electrical shock, make certain that it is only connected to a properly grounded receptacle. Before initiating any work disconnect power to prevent electrical shock. In case of pump failure, the motor housing and or the pumped fluid may carry high voltage to components normally considered safe.

Set the Glycol Feeder "GE-50-1" on a secure and level base. Connect the flexible hose supplied with the feeder to your system connection point. Use a union and isolation valve (not supplied) to allow for future service.

**NOTE:** Relief and drain valves may be added to the GE-50-1 tank. Any holes needed for entry of these items should be cut into the side of the tank. Do not go through the cover. The cover should remain removable.

Fill the GE-50-1 with fluid. The unit is suitable for water or glycol/water solutions of up to 50% glycol concentration.

### Operation Instructions

Leave the field installed isolation valve (not supplied) closed until the GE-50-1 has been cycled and checked for leaks.

Plug in the GE-50-1 to an approved electrical outlet. The pump will start and charge the pressure tank and stop automatically. Check that all joints are tight to ensure that there are no leaks.

The pressure switch integral to the pump is factory set at 60 PSI. It turns on at 45 PSI  $\pm$  5 PSI. The pressure relief is factory set at 100 PSI.

Fill your system. Slowly open the isolation valve between your system and the GE-50-1.

**NOTE:** The GE-50-1 is for glycol make-up only not to fill systems. The pump does not have a high flow rate. Using it to fill large systems will cause unnecessary wear on the pump and will void the warranty.

Once the system is filled to the correct pressure, make sure that the fluid level is adequate in the storage tank and record the level. The GE-50-1 has a 55 gallon tank and Neptune recommends that the tank is filled approximately 2/3's full.

### Maintenance Instructions

Periodically check the fluid level in the tank and examine the GE-50-1 to make sure that it is clean and all the joints are tight. The strainer on the suction hose should also be checked at that time.

PUMP SPECIFICATIONS:

Neptune Part No.: 127170

Pump Design: Positive Displacement

Check Valve: 2-Way Operation, Prevents Reverse Flow & 6 Feet Head forward Flow

Motor: Permanent Magnet, Thermally Protected

Voltage: 115 VAC

Pressure Switch: Adjustable Shut-Off (Range 40-60 PSI) Factory Set @ 60 PSI, turn On 45 PSI ±5 PSI

Prime: Self-Priming Up to 9 Feet Vertical, Max. Inlet Pressure 30 PSI

Ports: 3/8-18 NPT Female

Weight: 4.34 Lbs.

Duty Cycle: Intermittent

Approvals: NSF / UL / CSA Listed

PUMP DIMENSIONS:

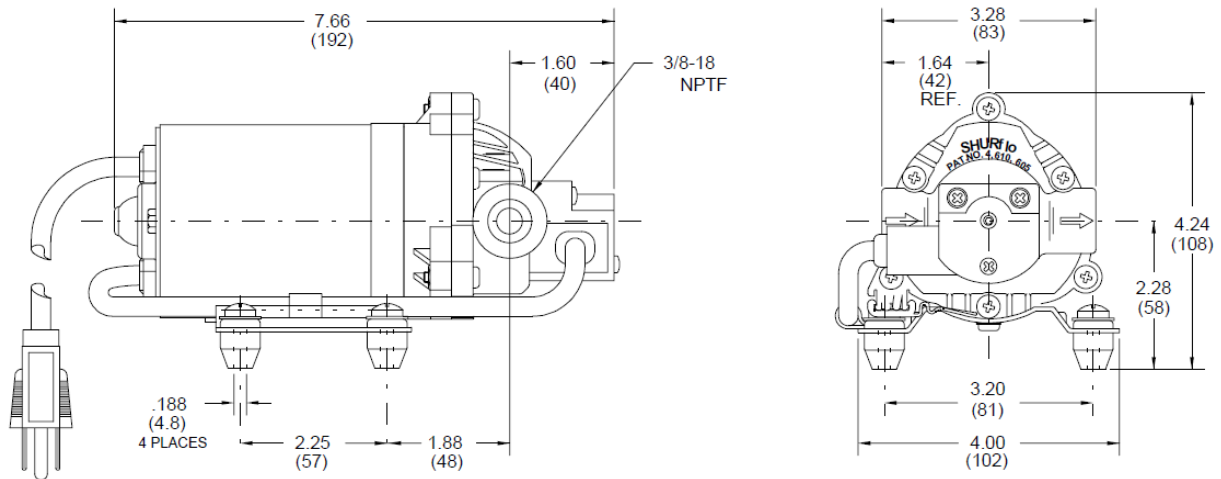

## PRESSURE SWITCH ADJUSTMENT

### NOTE:

The pressure switch is pre-set at the factory to the correct pressure for a particular pump model. Refer to the pump motor label for the maximum pressure rating.

A typical pressure switch has a “differential” pressure of 15 to 20 PSI. For example, a 60 PSI pump will turn off when it reaches 60 PSI. As liquid is needed, the output (side) of the pump is opened. This causes a pressure drop inside the pump pressure switch. When the pressure has dropped 20 PSI, the pump will turn on automatically. This will occur at a line pressure of 45 PSI. Both the “turn on” and “turn off” points typically have a tolerance of  $\pm 5$  PSI.

Notes on pressure use:

1. The “low profile” switch is connected to the pump head by two screws, 180 degrees apart. The 5/64” Allen head adjustment screw is located under the pressure switch decal, in the center of the switch body. Some versions of this switch have a Phillips head screw for adjustment.
2. The “mini-micro” switch is connected to the pump head by three screws. The 5/64” Allen head adjustment screw is visible at the end of the pressure switch.
3. Never adjust pressure switch above by-pass point as the motor may not shut off.
4. Pressure switch adjustment does not affect flow.

To properly adjust the pressure switch a “test bench” is necessary. All that is needed is a 1/2” ball valve, 0–120 PSI gauge, water, bucket, power source, 5/64” Allen key and various plumbing parts.

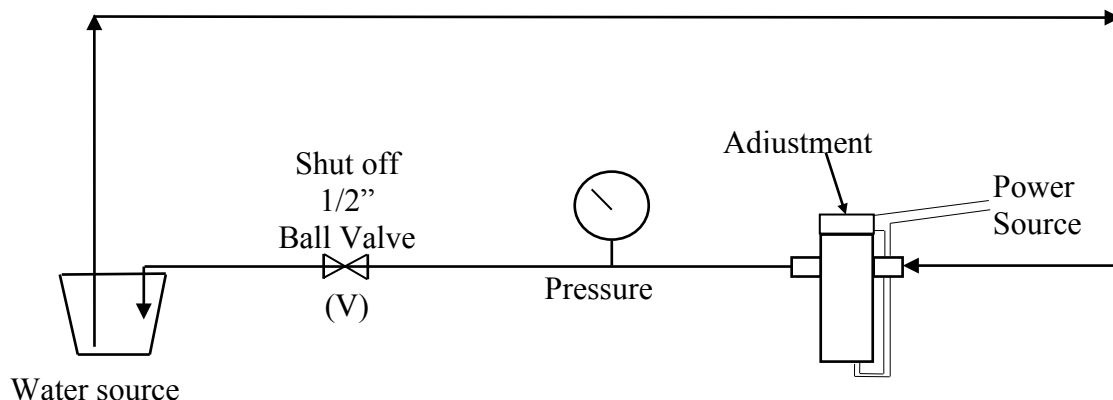

Adjustment Procedure:

CAUTION: Never adjust a pressure switch higher than the pump rating as listed on the pump motor label.

- A) With the discharge valve (V) open, start the pump. Let it run until all air is expelled out of the “test bench” plumbing system.
- 1) Open the 5/64” Allen set screw (ccw) approximately six turns.
- B) Slowly close the discharge valve (V) until the pump starts to cycle on/off. Look at the P.S.I. gauge. If PSI is lower than nameplate pressure rating, turn the 5/64” screw in (cw) approximately 2 to 3 turns.
- 1) Open the valve and repeat step “B” except turn in (cw) (the 5/64” screw) only 1 turn.
  - 2) Keep repeating Step “B” until pump shut off occurs at rated PSI. (60 ±5 PSI).
- C) To check pressure switch “differential” start pump and open discharge valve (V).
- 1) Close discharge valve (V) (pump should shut off at rated PSI).
- D) Very slowly open discharge valve (V). Watch the PSI gauge; as pressure drops (approximately 20 PSI), the pump should start.
- 1) If necessary, adjust 5/64” screw in or out approximately 1/2 to one turn to “fine tune” both turn on or turn off pressure.
  - 2) Repeat step “B” – if necessary.

Remember: both turn on and turn off points have a ±5 PSI range.

**SYSTEM CONNECTION SCHEMATIC**

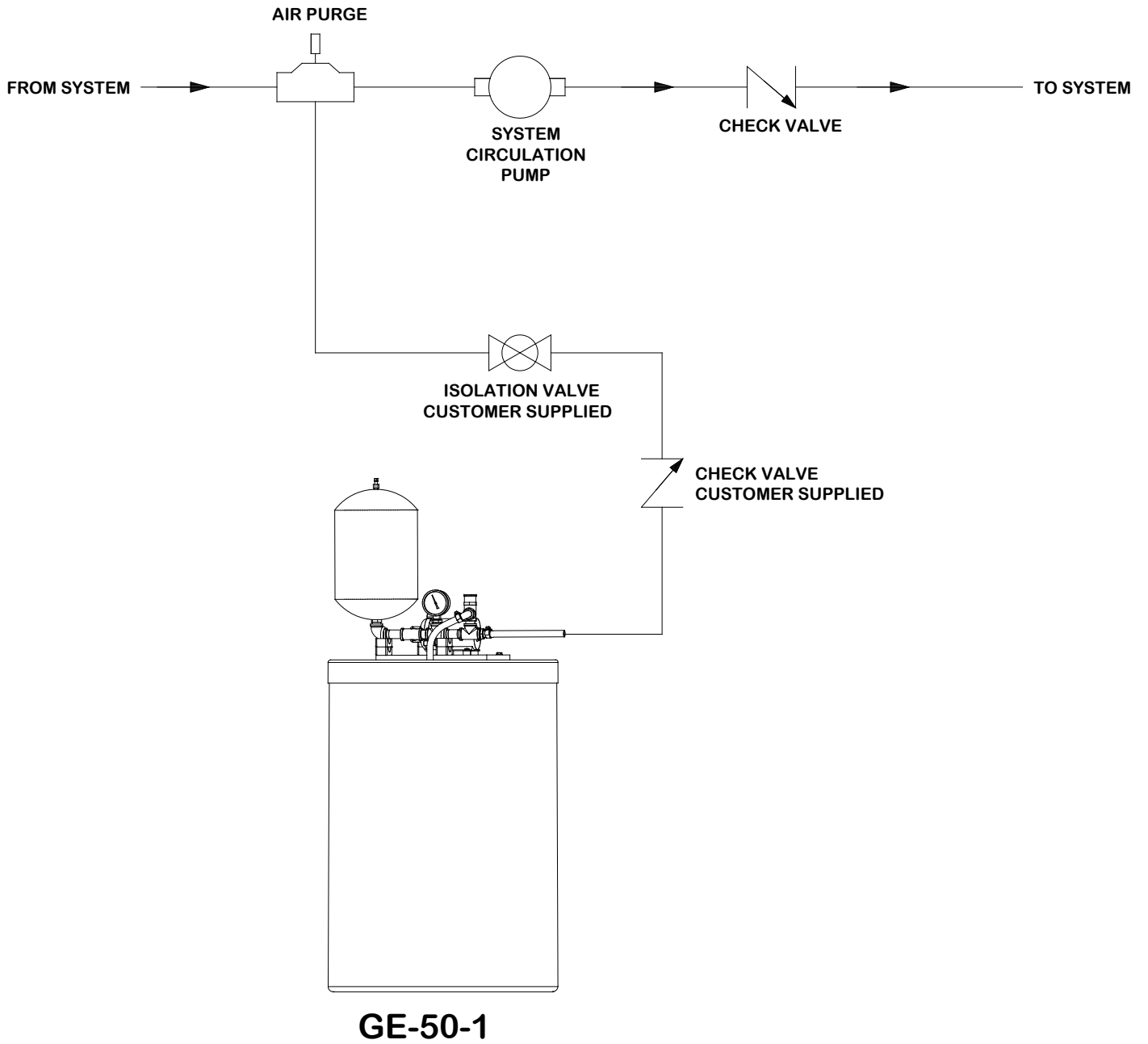

## **PARTS ORDERING INSTRUCTIONS**

**Send all orders or inquiries for parts to:**

Parts Department  
Neptune Chemical Pump Company  
295 Dekalb Pike  
North Wales, PA 19454  
Tel.: 215-699-8700  
1 -888-3NEPTUNE (888-363-7886)  
FAX: 215-699-0370  
Web: [www.neptune1.com](http://www.neptune1.com)  
Email: [pump@neptune1.com](mailto:pump@neptune1.com)

**NOTE:** PLEASE SUPPLY MODEL OF THE UNIT.



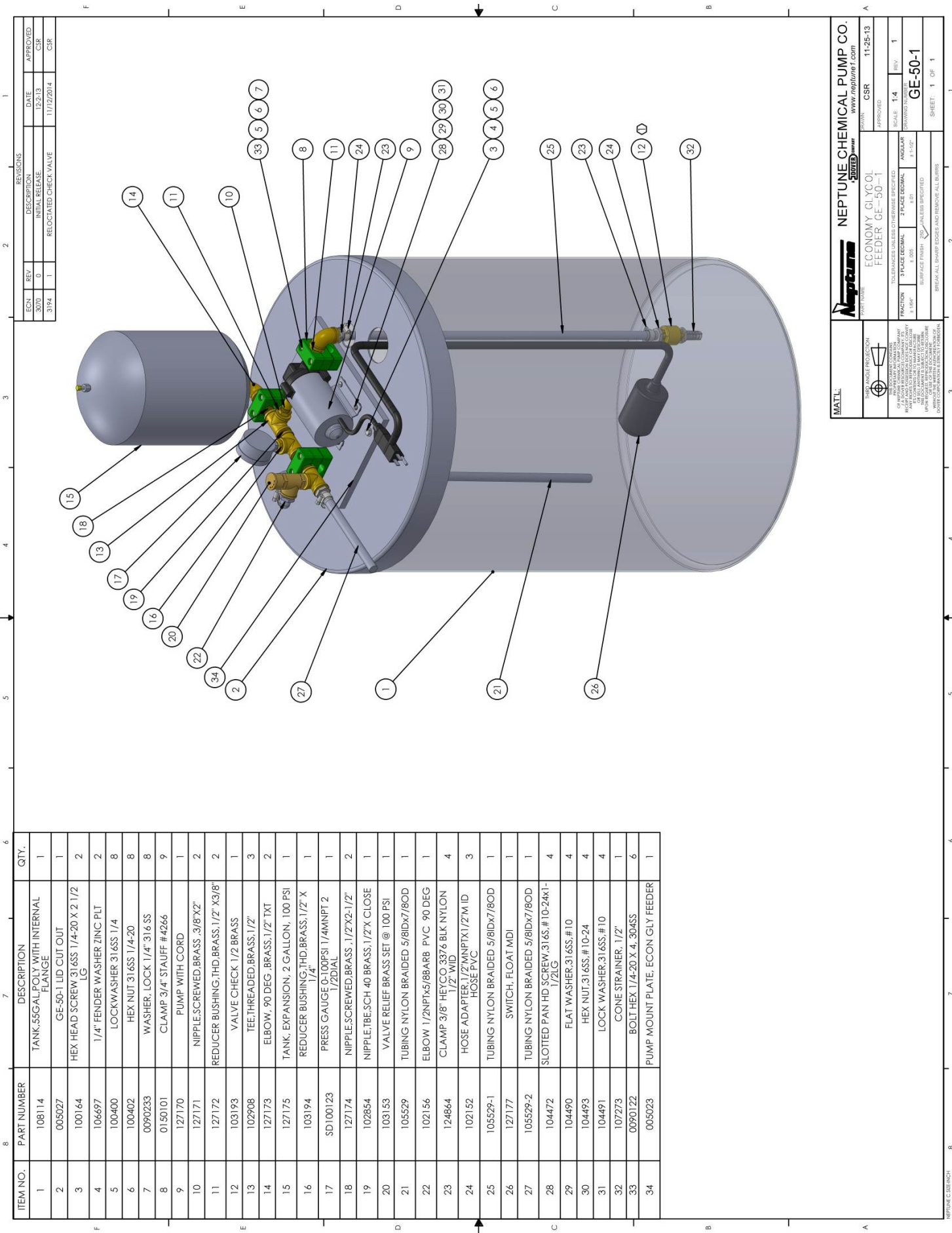

ITEM NO.	PART NUMBER	DESCRIPTION	QTY.
1	108114	TANK,55GAL,POLY WITH INTERNAL FLANGE	1
2	005027	GE-50-1 LID,CUT-OUT	1
3	100164	HEX HEAD SCREW,31.6SS,1/4-20 X 2 1/2 LG	2
4	106697	1/4" FENDER WASHER,ZINC,PLT	2
5	100400	LOCKWASHER,31.6SS,1/4	8
6	100402	HEX NUT,31.6SS,1/4-20	8
7	0090233	WASHER,LOCK,1/4" 31.6 SS	8
8	0150101	CLAMP,3/4" STAUFF #4266	9
9	127170	PUMP WITH CORD	1
10	127171	NIPPLE,SCREWED,BRASS,3/8"X2"	2
11	127172	REDUCER BUSHING,THD,BRASS,1/2" X3/8"	2
12	103193	VALVE CHECK,1/2 BRASS	1
13	102908	TEE,THREADED,BRASS,1/2"	3
14	127173	ELBOW,90 DEG, BRASS,1/2"X1/2"	2
15	127175	TANK, EXPANSION, 2 GALLON, 100 PSI	1
16	103194	REDUCER BUSHING,THD,BRASS,1/2" X 1/4"	1
17	SD100123	PRESS GAUGE 0-100PSI 1/4MNPT 2 1/2DIAL	1
18	127174	NIPPLE,SCREWED,BRASS,1/2"X2-1/2"	2
19	102854	NIPPLE,TE,SCH,40 BRASS,1/2"X CLOSE	1
20	103153	VALVE RELIEF BRASS SET @ 100 PSI	1
21	105529	TUBING NYLON BRAIDED 5/8IDx7/8OD	1
22	102156	ELBOW 1/2NPTx5/8BARB PVC 90 DEG	1
23	124864	CLAMP 3/8" HEYCO,337.6 BLK,NYLON 1/2" WID	4
24	102152	HOSE ADAPTER,1/2"MNPTX1/2"MNPT HOSE PVC	3
25	105529-1	TUBING NYLON BRAIDED 5/8IDx7/8OD	1
26	127177	SWITCH, FLOAT MDI	1
27	105529-2	TUBING NYLON BRAIDED 5/8IDx7/8OD	1
28	104472	SLOTTED PAN HD SCREW,31.6S,#10-24X1-1/2LG	4
29	104490	FLAT WASHER,31.6SS,#10	4
30	104493	HEX NUT,31.6SS,#10-24	4
31	104491	LOCK WASHER,31.6SS,#10	4
32	107273	CONE STRAINER, 1/2"	1
33	0090122	BOLT HEX,1/4-20 X 4, 304SS	6
34	005023	PUMP MOUNT PLATE, ECON GLY FEEDER	1

ECH	REV	DESCRIPTION	DATE	APPROVED
3070	0	INITIAL RELEASE	12-2-13	CSR
3194	1	RELOCATED CHECK VALVE	11/17/2014	CSR

**NEPTUNE CHEMICAL PUMP CO.**  
[www.neptune.com](http://www.neptune.com)

**NEPTUNE**  
 ECONOMY GLYCOL FEEDER GE-50-1

APPROVED: CSR 11-25-13

SCALE: 1:4

FRACTION: 3/16" DECIMAL 2 PLACE DECIMAL ANGULAR

TOLERANCES UNLESS OTHERWISE SPECIFIED

FINISH: 31.6SS: # 300 31.6SS: # 300 31.6SS: # 300

BLANKET FINISH UNLESS SPECIFIED

REPLACE ALL SHARP EDGES AND REMOVE ALL BURRS

SHEET: 1 OF 1

## TROUBLE SHOOTING CHART

<b>SYMPTOMS</b>	<b>CAUSES</b>	<b>REMEDIES</b>
1. Pump Will Not Start	A. Fluid level in tank is low.	A. Add fluid. Check for cause of fluid loss.
	B. Thermal fuse tripped.	B. Allow pump to cool down. Remember is designed for intermittent use.
	C. Power unplugged or loose connection.	C. Plug in power or fix faulty electrical connection.
	D. Pressure switch out of adjustment.	D. Adjust pressure switch according to Instructions in manual.
	E. Faulty pressure switch.	E. Replace pressure switch.
	F. Pump failure.	F. Replace pump.
2. Pump will not shut off	A. Air lock in pump.	A. Purge air from system.
	B. Leak in system or pump.	B. Inspect system and repair leak.
	C. Faulty pressure switch.	C. Replace pressure switch.
3. Pump will not prime	A. Fluid level in tank is too low.	A. Add fluid. Check for cause of system loss.
	B. Strainer on inlet is blocked.	B. Clean strainer.
	C. Product in tank too thick Congealed.	C. Clean strainer and check concentration of glycol mixture.
	D. Inlet tubing leak is drawing air.	D. Repair leak and replace tubing if Necessary.
	E. Inlet/outlet tubing is severely Restricted.	E. Replace tubing.
4. Noisy / Rough operation	A. Pump is overloaded and pressure Switch is not cutting out.	A. Replace pump.
	B. Pump pressure switch cutting out at very high pressure.	B. Adjust pressure switch to lower pressure.
	C. Loose screws on pump.	C. Tighten screws.
	D. Feeder is piped with rigid pipe Causing noise to transmit.	D. Re-pipe with PES or plastic pipe.
5. Feeder Leaking	A. Loose fittings.	A. Tighten fittings.
	B. Pump has punctured diaphragm.	B. Replace pump.

6. System pressure low	<ul style="list-style-type: none"> <li>A. Fluid level in tank is low.</li> <li>B. Breaker</li> <li>C. Pressure switch is out of adjustment.</li> <li>D. Pressure Relief Valve adjusted to low (item 17).</li> <li>E. Faulty pressure switch.</li> <li>F. Power unplugged or loose electrical connections.</li> <li>G. Pump failure.</li> </ul>	<ul style="list-style-type: none"> <li>A. Add fluid. Check system for cause of loss.</li> <li>B. Flip breaker on.</li> <li>C. Adjust pressure switch per adjust procedure.</li> <li>D. Remove cap turn in screw clockwise to increase pressure.</li> <li>E. Replace pump.</li> <li>F. Plug in or repair electrical connection.</li> <li>G. Replace pump.</li> </ul>
7. System pressure high	<ul style="list-style-type: none"> <li>A. Pressure switch is not adjusted properly.</li> <li>B. Pressure Relief Valve adjusted to high (item 17).</li> </ul>	<ul style="list-style-type: none"> <li>A. Adjust pressure switch per adjust procedure.</li> <li>B. Remove cap turn in screw counter clockwise to decrease pressure.</li> </ul>
8. Pump Cycles Continually	<ul style="list-style-type: none"> <li>A. Air is being removed from system and pump is making up fluid.</li> <li>B. Leak in system.</li> <li>C. Bladder in expansion tank is broken (item 12).</li> </ul>	<ul style="list-style-type: none"> <li>A. No action required.</li> <li>B. Inspect system and repair leak.</li> <li>C. Replace expansion tank.</li> </ul>

