

OPERATING AND INSTALLATION INSTRUCTIONS



**Air-Operated Double
Diaphragm Pumps
made of
stainless steel**

**Modular
Metal
Series**

MM 15

MM 25

MM 40



Original Instruction
Read carefully before pump installation

CONTENTS

	Page
Introduction	3
General description of the machine, appropriate use and residual dangers	3
Storage	3
Code system	4
Operation in explosion-proof areas	5
Technical data	7
Performance charts	8
Installation	9
Recommended installation	9
Start-up operations	9
Torque values	10
Safety instructions	10
Additional temperature hints	12
CIP and SIP cleaning	13
Maintenance	13
Required Tools	13
Disassembly	13
Hints for assembly	15
Troubleshooting	16
Spare part list	18
Spare part list USP	19
Exploded view	20
Dimensions	21
Optional equipment	22
Stroke counting (code C2, C3, C4)	22
Diaphragm monitoring (code D1, D3)	22
Diaphragms made of modified PTFE (code P)	23

INTRODUCTION

ALMATEC air-operated diaphragm pumps are constructed according to the state of the art and they are reliable. Imminent danger by operating error or misuse can lead to damages of properties and/or persons. The pumps are to be applied for the intended use and in a safety-related proper condition only.

Each person working on the ALMATEC air-operated diaphragm pumps concerning installation, start-up, handling or maintenance has to read this manual completely and in an attentive way and has to follow all mentioned procedures and safety notes.

GENERAL DESCRIPTION OF THE MACHINE, APPROPRIATE USE AND RESIDUAL DANGERS

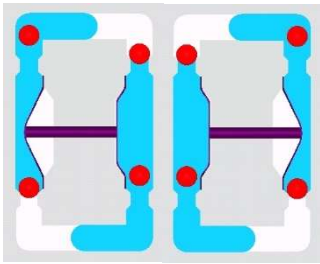

ALMATEC Modular Metal (MM) pumps are oscillating positive displacement pumps and are based on the functional principle of double diaphragm pumps. The basic configuration consists of two external side housings with a center housing between them. Each of the side housings contains a product chamber which is sealed against the center housing by a diaphragm. The two diaphragms are interconnected by a piston rod. Directed by an air control system, the diaphragms are alternately loaded with compressed air so that they move back and forth. In the first figure, the compressed air has forced the left-hand diaphragm towards the product chamber and displaced the liquid from that chamber through the open valve at the top to the discharge port. Liquid is simultaneously drawn in by the right-hand diaphragm, thus refilling the second product chamber. When the end of the stroke is reached, it reverses automatically and the cycle is repeated in the opposite direction. In the second figure, liquid is drawn in by the left-hand diaphragm and displaced by the right-hand diaphragm.

The appropriate use of an Almatec air-operated diaphragm pump of the Modular Metal refers to the liquid transport taking into account the operation parameter mentioned in this manual and in compliance of the given terms for commissioning, operation, assembly, disassembly and maintenance.

Even if all necessary safety measures described in this manual have been met, a residual danger exists by leakages or mechanical damages. At sealing areas or connections liquid can be released uncontrollably then.

STORAGE

In general the ALMATEC pump is delivered operational and packaged. If the unit is not installed right away, proper storage conditions are important for a trouble free operation later. The pump has to be protected from wetness, coldness, dirtying, UV-radiation and mechanical influences. The following storage conditions are recommended:

- Steady ventilated, dust and vibration free storage room
- Ambient temperature between 15°C and 25°C with a relative humidity below 65%
- Prevention of direct thermal influences (sun, heating)

CODES SYSTEM

PSG Germany GmbH is certified as a modern, quality-orientated enterprise according to DIN EN ISO 9001 and 14001. Before release for dispatch, any pump of the Modular Metal has to undergo an extended final control. The performance data registered during this are archived in our records and can be read back at any time.

As a general rule in the countries of the EU only such machines are allowed to take into operation, which are determined to meet the regulations of the EU machinery directive, the harmonized standards, European standards and the respective national standards. Hence the operator has to verify whether the ALMATEC pump manufactured and delivered properly according to the customer's order meets the mentioned requirements.

Therefore make sure, before putting the pump into operation, that the pump and the used materials of construction are suitable for the provided application and the installation site. To check this, the exact pump code is required. This code, the serial number and the year of construction are noted on the identification plates on the pump itself.

Example for a pump code:

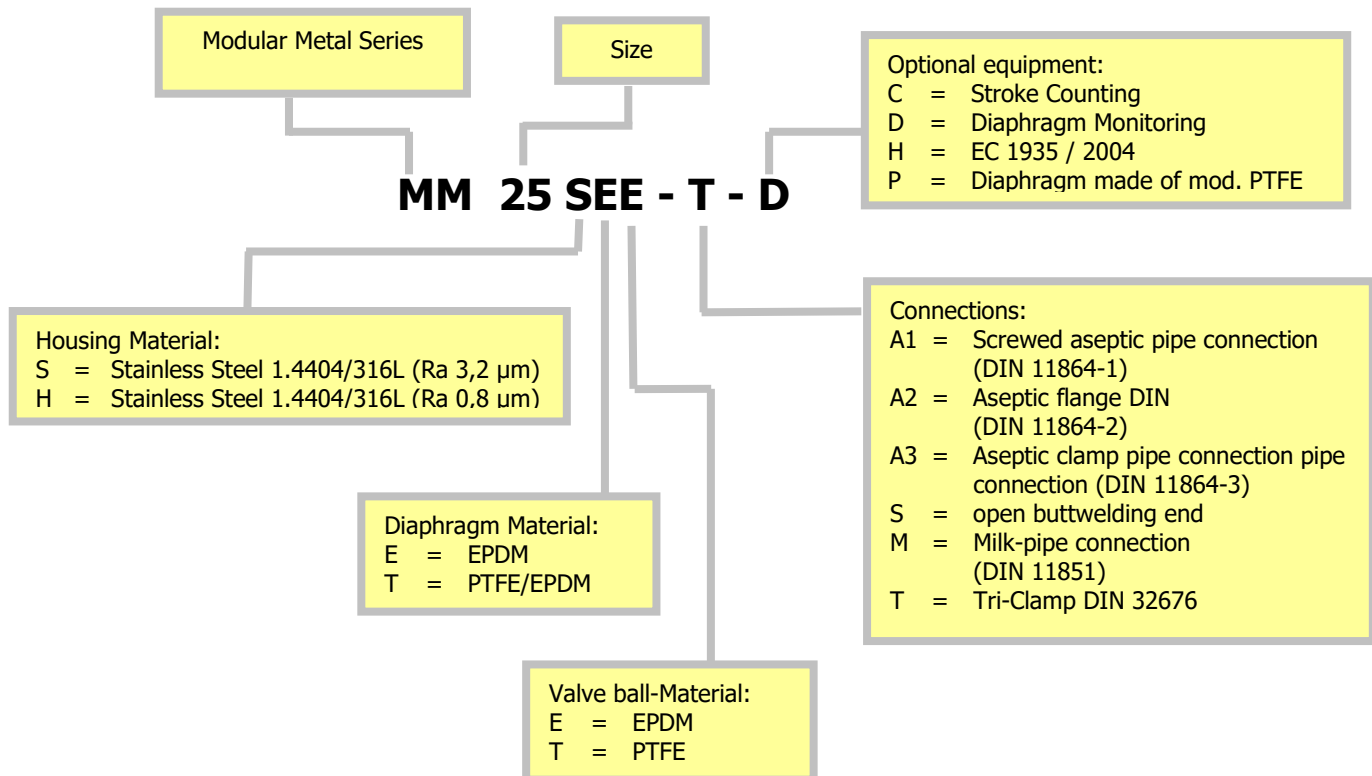

The number in brackets, which is added to every part mentioned in the following explanations, refers to its position in the spare part list and the exploded view

OPERATION IN EXPLOSION-PROOF AREAS AND FOR FLAMMABLE LIQUIDS

For inflammable liquids as well as for applications in explosion-proof areas, Modular Metal pumps have to be grounded to one of the M6 tapping holes located in the frame [7]. The grounding connection must have a minimum cross-section of 6 mm². All other housing parts are connected in a conductive way, therefore it is not necessary to ground single parts.

Grounded Modular Metal pumps are suitable to be used in potentially explosive atmospheres of category 2 and 3 ("Zone 1" and "Zone 2" respectively), atmosphere G/D, which are subject to the scope of EU Directive 2014/34/EU.

Conductive diaphragms (material code 68, 70, 72) can be used without restriction for pumping liquids in all explosion groups. If non-conductive diaphragm materials are used (material code 67, 98), explosion group IIB applies within the pump for pump size MM 15 up to including MM 25 (regardless of the installation site). Following protective measures must be taken for pump size MM 40 as examples:

- exclusive use of water-miscible or conductive pump media or
- Avoidance of dry running through operational measures or
- inerting during dry running with nitrogen, water, carbon dioxide, etc. following the pumping operation.

Pipelines and product connections must be grounded separately. To avoid ignition hazards, the formation of dust deposits on the units must be prevented. Repairs in hazardous areas may only be carried out after careful examination of the feasibility and only with appropriate tools and by trained specialist personnel.

The ATEX marking according to Directive 2014/34/EU can be found in the enclosed Declaration of Conformity and the corresponding sticker on the pump or damper.

The interfaces for electrical accessories have been considered and do not represent a new potential ignition source.

The type of protection "**c = design safety**" was applied in accordance with guideline EN ISO 80079-37.

SPECIAL OPERATING CONDITIONS	MM 15	MM 25	MM 40
Permissible ambient temperature (°C) °F		(-10 – 50) 14 - 122	
Permissible temperature of compressed driving air (°C) °F		(0 – 50) 32 - 122	
Maximum driving/operating pressure (bar) psi		(7) 101,5	
Maximum operating temperature (X): (°C) °F:		(80) 176	

The ATEX marking for gases and dusts is defined as follows according to 2014/34/EU:

In order to enable the optimum and flexible design of an ATEX pump to the customer-specific application, a differentiation is made in the marking between the installation location of the pump (hazardous area outside the pump) and the inside of the pump (hazardous area inside the pump).

Equipment category G (gases, mists, vapors)

Installation site: Category G

Inside the pump: Category G

Conductive ALMATEC air-operated diaphragm pumps may generally be used in explosion group IIC at the installation site (potentially explosive area outside the pump), since the solid housings are made of dissipative materials and the entire pump is grounded.

ATTENTION! Inside the pump, the permitted explosion group varies depending on the diaphragm material used:

When using *non-conductive diaphragms*, explosion group IIB applies inside the pump:

⊕ II 2/2 G Ex h IIB/IIC T6...T4 Gb/Gb X (inside the pump/installation site)

When using *conductive diaphragms*, explosion group IIC applies inside the pump:

⊕ II 2/2 G Ex h IIC/IIC T6...T4 Gb/Gb X (inside the pump/installation site)

Equipment category D (dusts)

Installation site: Category D

Inside the pump: Category G

Conductive ALMATEC air-operated diaphragm pumps may generally be used in dust group IIIC at the installation site (potentially explosive area outside the pump; equipment category D).

ATTENTION! Inside the pump (equipment category G), the approved explosion group varies depending on the diaphragm material used:

When using *non-conductive diaphragms*, explosion group IIB applies inside the pump:

⊕ II 2/2 D Ex h IIB/IIIC T 70°C...130°C Gb/Db X (inside the pump/installation site)

When using *conductive diaphragms*, explosion group IIC applies inside the pump:

⊕ II 2/2 D Ex h IIC/IIIC T 70°C...130°C Gb/Db X (inside the pump/installation site)

TECHNICAL DATA

	MM 15	MM 25	MM 40
Dimensions mm (inch): Length	see page	see page	see page
Width	18	18	18
Height			
Nominal port size Air connection (BSP)	1/4"	1/4"	1/4"
Weight – kg (lbs)	14 (31)	33 (73)	82 (181)
Max. particle size of solids - mm (inch)	4 (0.16)	7 (0.28)	11 (0.43)
Suction lift, dry - mWS (ftWC)	3 (9.8)	3 (9.8)	4 (13.1)
Suction lift, wet - mWS (ftWC)	9 (29.5)	9 (29.5)	9 (29.5)
Max. driving and operating pressure - bar (psig)	7 (100)	7 (100)	7 (100)
Max. operating temperature - °C (°F) **	80 (176)	80 (176)	80 (176)
Theoretical displacement volume per single stroke (l)	0,15	0,51	1,37
Sound pressure level acc. to DIN 45635, part 24, depending on the operating data [dB (A)]:			
driving pressure 3 bar	68-71	69-71	76-78
driving pressure 5 bar	73-75	71-75	77-80
driving pressure 7 bar	74-78	73-76	78-82

** Center block in PE-conductive



PERFORMANCE CHARTS

The data refer to water (20°C), without using of a pulsation dampener and in accordance with DIN EN ISO 9906.

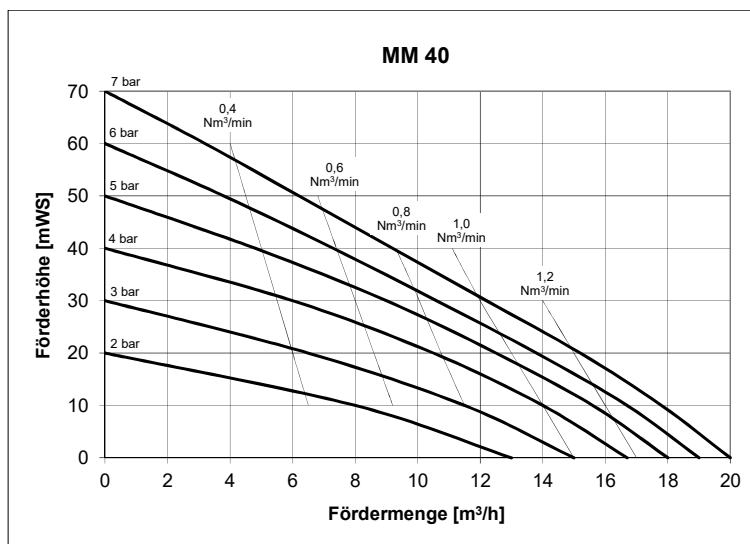
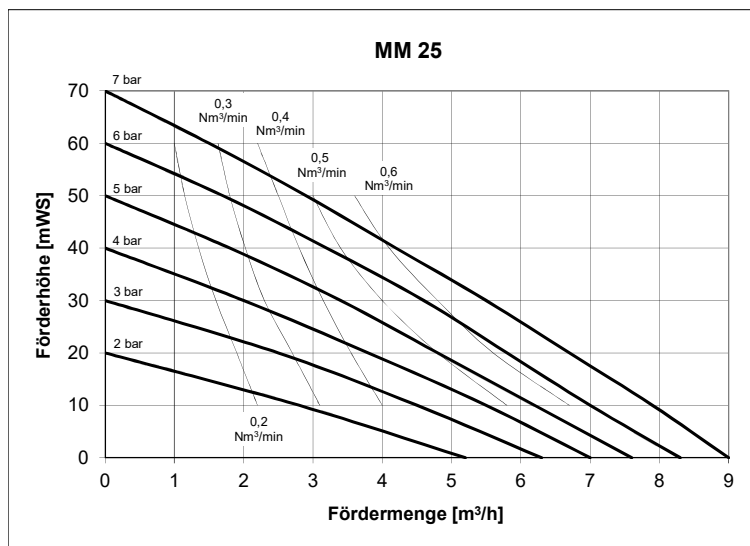
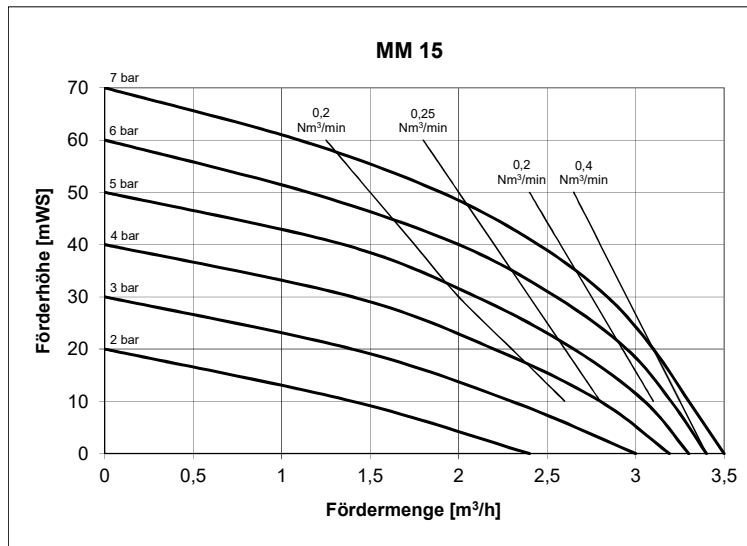

INSTALLATION

Recommended installation

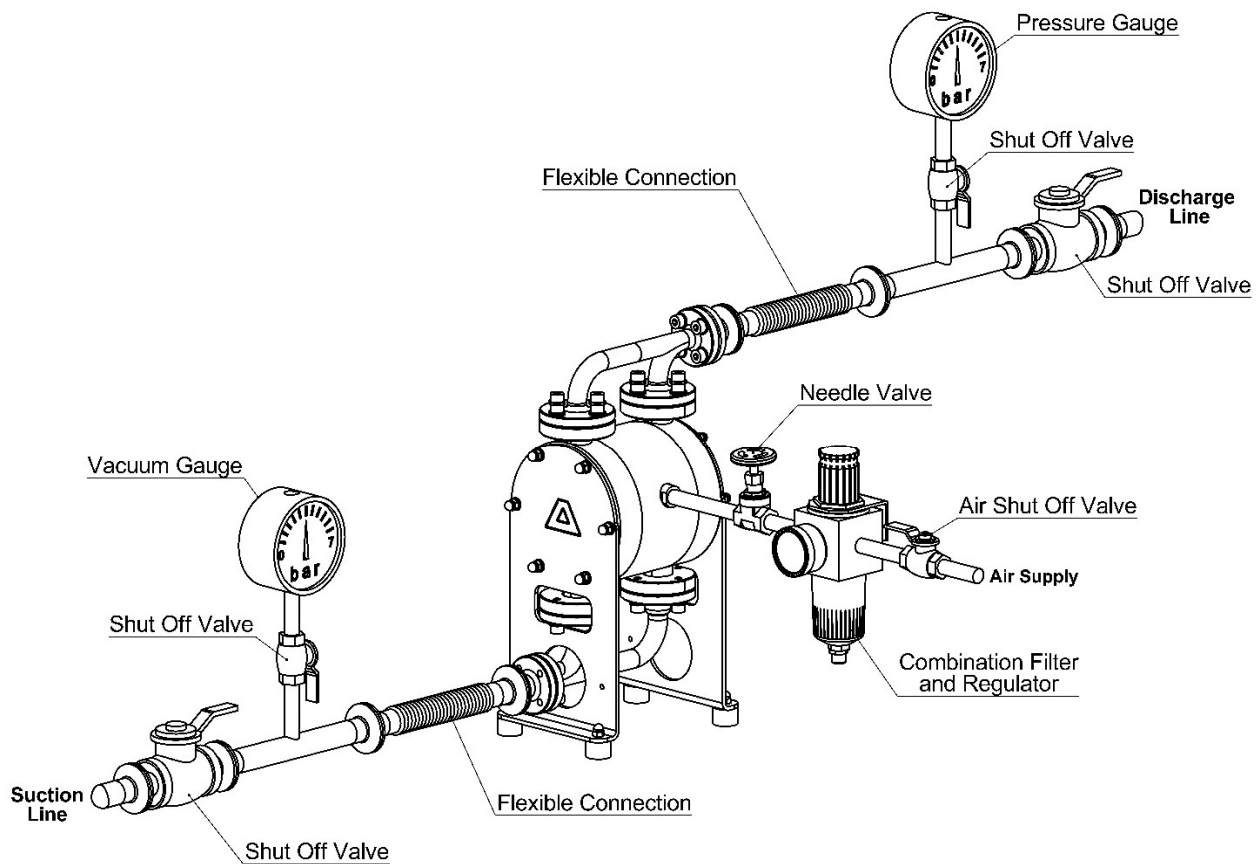

Start-up operations

In general, the pump has to be connected load free. Neglecting this causes leakage and maybe even damages. To avoid vibrations, pulsation dampers and compensators are recommended. Before connecting the pump, take the yellow blind plugs out of the suction and discharge connections [5,6] as well as the air inlet [24]. The air inlet is located below the bilingual sticker with safety instructions.

The operator is responsible for an adequately stability and an appropriate fixation of the piping according to the state of the art. To facilitate the installation and maintenance shut off valves should be installed right before and after the pump. The nominal width of the connection pipes has to be chosen in accordance to the connections of the pump. A smaller piping can cause cavitation (suction line) as well as a loss of performance (suction and discharge line). In case the pipe is too big, the dry suction capacity of the pump can decrease. Connect the suction line to the lower manifold [6]. Hosepipes should be suitably armoured. A suction line continuously rising will prevent the formation of air locks in the line which would affect the suction lift. The discharge line has to be connected to the upper manifold [5].

The air inlet [24] is located in the middle of the center block [21]. When delivered it is covered by a bilingual sticker with safety instructions, which can be easily removed. Before installation, make sure that the air supply pipe is free of solids. To supply the pump with driving air sufficiently, the pipe diameter should match the size of the air inlet. Take care that no dirt or particles can intrude into the pump during the connection, as these can accumulate inside the pump and can cause malfunctions. An air filter [25] directly behind the air inlet [24] prevents the entry of bulk particles.

The integrated air control system *PERSWING P*® [22] is a precision-control that requires oil-free, dry and clean compressed air for optimal function. If humidity is expected, a water separator or air dryer has to be fitted to protect the pump from blocking by ice. The ideal condition is the dewpoint of air at -20°C. In humid surroundings, icing from the outside may occur despite the driving air is dried. If so, a prolonged waste-air-exhaust (ca. 500 mm by pipe or hose, connection size in request) can be helpful. When installing the pump into boards or cabinets, it has to be ensured that cold air does not get caught behind the muffler. In applications with a tendency to freezing at the waste air exhaust, good experiences in practise have been achieved by pre-heating the driving air to increase the distance to the dew point of the air. Doing so, it has to be considered that the driving air temperature generally may not exceed 50°C to avoid expansion and sticking effects on the air side. This max. air temperature is a well valid when using a compressor producing warm air which is e.g. often true for truck compressors.

The pressure of the driving air should be limited to the amount required to meet the performance needed. Excessive pressure increases both the air consumption and the wear of the pump. The pump is regulated by tuning the flow rate of the air. For a proper operation at the lower performance range the regulation via a needle valve is recommended. An empty pump has to be driven slowly (e.g. via a needle-valve). The pump starts automatically. ALMATEC Air-Operated Double Diaphragm Pumps are self-priming when dry, thus it is not necessary to fill the suction line of the pump. During slow operation of the pump the dry suction lift is better than during high stroke frequency. The suction lift capacity of a liquid-filled pump, however, is much higher. The pump is appropriate for running dry during slow operation. Dry running at high stroke frequency causes premature wear. The pumps can briefly (up to max. one hour) be operated against a closed discharge line. Throttling on the suction side may damage the pump. When the pump operation has been stopped by a closed discharge, the pressure equilibrium of the diaphragms must be ensured. This can be achieved by keeping the pump connected to the air supply pressure; for longer stoppage, the pump must be released from the pressure within the system on both fluid side and air supply side.

Torque values



Before putting the pump into operation as well as after some hours of operation, the housing bolts [14] have to be fixed according to the torque data of the following schedule, as the elements of construction "settle". As a reminder the air inlet [24] is covered by a corresponding sticker at delivery. Fixing the bolts is necessary as well after longer periods of stoppage, at extreme temperature variations, after transport and dismantling the pump. In case of temperature varying between extremes or high temperature difference between the liquid and the surrounding, the housing bolts should be controlled more frequently (interval proposals are available on request).

Pump size	MM 15	MM 25	MM 40
Torque values for housing bolts (Nm)	12	20	20

Safety instructions



- Installation, operation, and maintenance by qualified staff only.
- Before start-up of the pump anyone should acquaint oneself with the explanations of the chapter troubleshooting (see pages 14/15). Only by this the defect quickly can be realized and eliminated in case of trouble. Problems which cannot be solved or with an unknown reason should be passed on to the manufacturer
- All wetted materials of the pump are appropriate for food-contact. A malfunction can however result in material contact to components of a pump that are not wetted during normal operation (e.g. air side parts in an AODDP or other parts in in rotational pump).



Therefore, we recommended to discard a batch of sensitive media after any malfunction as usual for pumps

- Before any maintenance and service procedures arising on the pump or on the optional equipments, the complete installation has to be turned off and protected against accidental turn on. This is possible by a lockable emergency stop for the air supply of the pump. Additional a danger sign against restart should be attached.
- Pressure tests of the plant a pump is included in may only be carried out with the pump disconnected from the pressure on both ports or by using the pressure the pump develops while operating. The load of a pressure in the plant may damage the pump
- AODD pumps must not be operated with a positive suction pressure.
- Depending on the conditions of operation, the liquid conveyed might escape from the pump through the muffler in case of a diaphragm rupture (in this case muffler has to be replaced). For further safety requirements the optional equipment diaphragm monitoring is recommended
- In case of a diaphragm rupture, it might be possible for the fluid pumped to intrude into the air side of the pump. In very adverse conditions - e.g. pressure within the fluid system during stopped air supply - the fluid might as well find its way into the air supply lines. To protect other devices like pulsation dampers or even pneumatic valves, it is recommended to protect the air supply line accordingly, e.g. via a non-return valve. This would as well avoid polluting the air supply line.
- The state of the muffler has to be inspected regularly, as a blocked muffler can be forced out of the pump. If this happens, damages of properties and/or persons cannot be excluded.
- If the product tends to settle, the pump has to be flushed regularly. For larger solids a filter has to be installed in the suction line.
- In case of delivery of hot liquids the wetted pump must not standstill for a longer time, because it could lead to temporary leaks in the valve area and to a blockade of the air control system.
- The relevant effective security advices have to be respected.
- Pools of liquid which appear in the near outer area of the pump have to be inspected on danger potential, if necessary safety measures are to be taken.
- Chemical and biological reactions in the product chamber of the pump (mixture of different substances) and the freezing of the liquid have to be avoided.
- Before starting to disassemble the pump, take care that the pump has been emptied and rinsed. Both ports piping are to be closed and drained if applicable. Further the pump has to be cut off from any energy on the air and product side. If the pump is being deported from the plant, a reference about the delivered liquid has to be attached. A template is available on the Almatec website
- Please respect the relevant additional security advices, if the pump has been used for aggressive, dangerous or toxic liquids (e.g. suitable protective equipment according to the safety data sheet of the liquid). In case of a diaphragm rupture, it is possible that residues of the liquid remain behind the diaphragms, in the area of the air control system and at the muffler, despite of several flushing processes. Hence, appropriate safety equipment according to the safety data sheet of the liquid is indispensable.
- Before putting the pump back into operation, the tightness of the pump has to be checked.
- Additional advice for handling sensitive Fluids: With correct material choice, all wetted parts inside the pump are made from materials appropriate for your fluid - selected types as well for food contact. A malfunction, however, might result in a contact of the fluid to components that are non-wetted during normal operation (e.g. inside the air section). Therefore, we recommend as usual for pumps, to discard the batch after a malfunction when handling sensitive fluids. Please consider that a conformity for food-contact solely refers to wetted materials themselves, NOT to a "Hygienic Pump Construction".
- Pumps of the Modular Metal series must not be submerged
- Air-operated diaphragm pumps can lead to bruises when lifting, sinking or assembling them. Appropriate accessories and safety equipments are to be used. Big and heavy modules have to be fixed and secured to lifting gears when transporting/replacing them.
- Especially when deliver critical liquids, wear parts, like diaphragms, should be replaced within a preventive maintenance.

- The use of non-original ALMATEC spare parts and structural changes lead to the lapse of the warranty immediately. When operating such a pump, damages of properties and/or persons cannot be excluded.
- The operation of the pump with nitrogen as driving gas is possible. In closed rooms sufficient ventilation must be provided.
- Possible electrical connections (e.g. when using optional equipment with controllers) may be executed by a qualified person only. The regulations of the respective manufacturers are to be followed,
- At any work arising it has to be made sure that no explosive atmosphere can appear. Appropriate safety equipment is recommended.
- Procedure for pump return: According to the requirements of our 14001-certification, every unit which is send to ALMATEC for diagnosis or maintenance reasons has to be accompanied by a filled out decontamination-sheet. Otherwise a processing is not possible. The decontamination-sheet is enclosed to this manual. Please pay attention to the further safety regulations.

Additional temperature hints

The temperature and pressure limitations listed on page 5 are solely based on mechanical temperature limits of the housing material used. Depending on the fluid pumped, the maximum safe operating temperature of the housing material can be reduced significantly.

A general aspect of lower temperatures is, that below 0°C (32°F) cold-brittling of the elastomers used within the pumps can results in accelerated wear. ALMATEC pumps can therefore be operated safely as well within low-temperature installations: However, with liquids below 0°C (32°F) accelerated wear of internal parts has to be accepted. Moreover, freezing, bogging or crystallisation of the fluid pumped must be avoided, especially within the pump.

Please consider, that viscosity and specific gravity of most fluids change with temperature (most often increasing at lower temperature). Depending on the application, this fact may not only result in result in a reduced flow rate, the pump may even be unable to prime the thicker and/or “heavier“ fluid any more.

In case of varying application temperatures, the housing bolt tension has to be controlled very thoroughly, as variations like these can change the effective tension of the housing bolts via the different thermal expansion characteristics of single.

CIP AND SIP CLEANING

Basic condition for the delivery of hygienic perfect and high-quality liquids is a clean pump. The design of the pump permits the CIP as well as the SIP cleaning. Despite the general restriction of temperature of 80°C (176°F) a brief operating (max. 30 minutes) to 130°C (266°F) for purification processes is permitted, in these cases the pump must run slowly (approx. 1-2 double strokes per second, e.g. sterilization with steam). If a cleaning liquid is used, this should be sucked by the pump itself without external pressure in the system. For explosion proof areas please see explanations on page 5.

MAINTENANCE

Only use original ALMATEC spare parts for repairs and / or preventive maintenance work. If this is not observed, the CE and ATEX markings, the declaration of conformity (s) and the guarantee claim for the pump will expire. All work on the pump may only be carried out with the appropriate tools and by trained specialist personnel.

Required tools

The general design of the ALMATEC Modular Metal pumps is simple. A plastic tool designed for the mounting of the air-valve [30] is delivered along with every pump.

	Tool list	Size	MM 15	MM 25	MM 40
Pos	Description	Kind of tool	Tool Size	Tool Size	Tool Size
2/3	Valve housing	Open end spanner	SW 27	SW 55	SW 80
5/6	Manifold discharge / suction side	Hexagonal spanner [DIN911]	6	8	10
8	Connection port discharge / suction side	Hexagonal spanner [DIN911]	6	6	6
14	Housing bolt, cpl.	Open-end/Box Wrench / Socket Spanner	10 mm	13 mm	13 mm
16	Nut, DIN 1587	Open-end/Box Wrench / Socket Spanner	10 mm	10 mm	10 mm
18	Sect screw, shaft, DIN 913	Hexagonal spanner	5 mm	6 mm	8 mm
24	Air inlet	Open end spanner	19 mm	27 mm	27 mm
30	PERSWING P® Air control system, cpl.	ALMATEC-Tool	1 15 901 54		

Disassembly

When dismantling a pump the mentioned procedures and safety notes on the pages 7-10 have to be considered generally. Please find the part number for any part in the spare part list.

First unscrew the muffler [26] out of the centre block [21]. Loosen the eight hexagonal screws [7] on the manifold discharge side [5] with hexagonal spanner (figure 12.1) and remove manifold discharge side [5]. By screwing out the valve housings [2] via open end spanner (figure 12.2 / 12.3), the complete discharge side of the pump is now disassembled.

Remove mount flanges [11], valve stop [12], valve balls [20] as well as O-Rings [4; 13].

Lay the pump on its back and unscrew the nuts of the housing bolts [14] on one side via socket spanner and remove frame [22]. Via loosening the two valve housings suction side [3], that connect the manifold suction side [6] with the side housings [1], the complete suction side of the pump can be taken off.

Remove frame [22]. Remove side housing [1]. Now, the complete discharge side, one side housing [1], one frame [22] and the complete suction side are removable. Unscrew and remove hexagonal screws [7] of the valve housing, suction side [6], to separate the clamp flanges [11] and the manifold suction side [6]. Remove valve stop [12], O-Rings [4; 13] and valve balls [20].



Figure 12.1

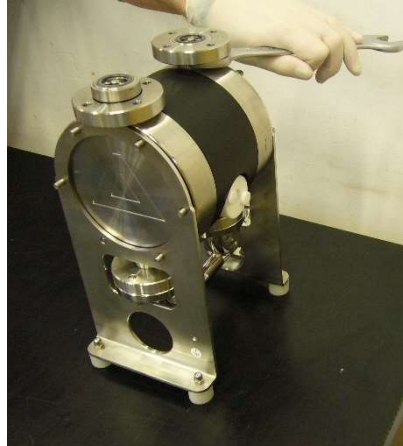

Figure 12.2



Figure 12.3



Figure 12.4



Figure 12.5



Figure 12.6



Figure 12.7

All these as well as the following steps need to be done with high care to ensure that the sealing surfaces in contact with the diaphragms are not damaged. Unscrew one diaphragm [19] counter-clockwise from the shaft [17]. Carefully pull out housing bolts [14]. After this, the second side housing [1] and the second frame [22] are accessible as well. Pull out the other diaphragm [19] from the center block [21] together with the shaft [17]. Screw set screw, shaft [18] with a hexagonal spanner out of the diaphragms [19] (figure 12.4). Remove piston rings and O-Rings of the shaft piston rings [23] out if their grooves (figure 12.5); do not damage edges in the center block [21]; A re-assembly of the same piston rings is impossible, they have to be replaced. Screw out air inlet [24]; screw the air filter [25] via major screw driver out of the center block [21]. To remove the *PERSWING P*® air control system [30], screw off both end caps using the plastic mounting tool supplied with the pump (figure 12.6). Take out main and pilot piston. Push out the air valve housing with the mounting tool turned around (figure 12.7).

Hints for assembly

The re-assembly of the components is principally carried out vice-versa to the dismantling. Here are some additional hints.

For the installation of the *PERSWING P*® [30] air control system, first screw in one end cap flushly into the center block [21]. Turn the center block [20] and insert one of the six O-rings air-valve housing into the end cap from the inside of center block [21]. Moisture the four O-rings of the air-valve housing with a bit of water and push the housing into the center block [21] using the mounting tool. Take care that it slips in softly. Do never insert the housing violently with a hammer. In case the housing cocks or hardly gets in, take it out again completely and start again. Insert the main piston and the pilot piston. Lay the sixth O-ring on the edge of the air valve housing and screw in the second end cap.



Figure13.1

To assemble a new piston ring of the shaft piston ring [23], carefully shape them like kidneys with locking ring pliers and insert the rings into the grooves in the center block [21] (figure 13.1); completely press the rings into the grooves smoothly using some round tool.



Figure 13.2

Screw the set screws shaft [18] into the diaphragms [19] and tighten them. Screw one diaphragm [19] with set screw shaft [18] into the shaft [17], insert it into the centre block [21], adjust the bores in the center block [21] to the diaphragm (turn slightly backwards if necessary) and fix it with the housing bolts [14] (figure 13.2). The sealing surfaces of the diaphragms [19] and the side housings [1] have to be absolutely clean and undamaged; mere small scratches can cause leaking (if necessary, smoothen the housing surfaces carefully with fine sandpaper). Push the pump housing [1] onto the housing bolts [14].

Screw the second diaphragm [19] into the shaft [17], adjust with the bores in the centre block [21] (turn slightly backwards if necessary) and carefully push the housing bolts [14] complete through the centre block [21]. Install the second side housing [1]. If necessary carefully compress the pump housings [1] and the centre block [21] by using a screw clamp. Set on frame [22] and tighten the housing bolts [14] only loosely.



Figure 13.3

Spray the threads of the ports of the valve housing [2] and side housings [1] with Teflon-Spray. Shove mount flanges [11] over the valve housing [2], screw valve housing [2] into side housing [1] and tighten via open end spanner. AFTER that, insert first valve ball [20], then valve stop [12] (figure 13.3). Set on manifold [2], align it and fix hexagonal screws [7] and Clamp flange [11] with hand force only. Now, tighten housing bolts evenly crosswise with the torque given on page 8 until the side housings [1] are in contact with the centre block [21]. After that, set on manifold, discharge side [5] and tighten with hexagonal screws [7]. Any further tightening of the bolts does not improve sealing but can deform the housing!

Before putting the pump back into operation, the tightness of the pump has to be checked.

TROUBLESHOOTING

Malfunction	Possible Reason	Solutions/Remarks
pump does not operate	no air supply air supply line blocked/closed muffler blocked working chambers blocked air control system defective discharge line blocked/closed	open air supply clean/open air supply clean/replace muffler remove blockage replace air valve system clean/open line
pump operates unsteadily	piston rings worn air control system worn diaphragm rupture air control system soiled ball valve blocked icing	replace piston rings replace air control system replace diaphragm, clean pump clean/replace air control system cleaning, removal of bulk particles improve air processing
air within liquid	suction line leaky container with liquid empty diaphragm rupture cavitation	seal suction line fill/new container replace diaphragm adapt suction lift, possibly install suction pressurized air chamber
insufficient discharge pressure	insufficient pressure/amount of driving air air supply line leaky air control system leaky ball valve worn more air consuming components	increase air supply check/repair air supply replace air control system check/replace ball valve increase pressure/amount of air
output decreases	air control system soiled icing air pressure drop suction line/inlet strainer soiled discharge line/outlet strainer soiled muffler blocked ball valve worn change in viscosity more air consuming components	clean/replace air control system improve air processing: dryer/filter ensure sufficient supply of air cleaning cleaning replace the muffler replace valve change back/adjust pump increase pressure/amount of air
pump stops itself	icing of the air control system air pressure too low air pressure drop discharge line blocked air filter blocked valve closed air control system defective wear/leaking of air control system diaphragm rupture ball valve blocked/worn	improve air processing: dryer/heater etc. increase air pressure ensure sufficient air supply clean discharge line clean air filter open valve replace air control system replace air control system replace diaphragm, clean pump clean/replace ball valve

Malfunction	Possible Reason	Solutions/Remarks
pumps operates, however suction capacity insufficient	<p>pump operates too fast operation beyond physical limits cavitation</p> <p>operation beyond pump capacity</p> <p>air cushion within suction/discharge line</p> <p>dry suction against discharge pressure</p> <p>valve filter within suction line closed</p> <p>valve filter within discharge line closed</p> <p>container with liquid empty</p> <p>vacuum inside the container</p> <p>wear of the check valves</p> <p>suction line leaky</p> <p>suction line blocked</p> <p>air pressure cushion at discharge</p> <p>ball valve blocked</p>	<p>start more slowly</p> <p>adjust installation</p> <p>check installation, check temperature, cool down</p> <p>adjust installation resp. install bigger pump</p> <p>bleed the line</p> <p>wet pump, start without pressure</p> <p>open valve/clean filter</p> <p>open valve/clean filter</p> <p>fill/new container</p> <p>bleed container</p> <p>replace valves</p> <p>seal suction line</p> <p>clean suction line</p> <p>bleed discharge line</p> <p>clean/replace valve</p>
insufficient suction capacity after pump repair	connections tighten incompletely	tighten/seal connections, clean sealing area
diaphragm overstrained	<p>pressure within the plant/system</p> <p>inadmissible vacuum</p> <p>icing</p>	<p>ensure that pressure is only developed by the pump itself, check plant/valves, replace diaphragms</p> <p>check suction line, open valve</p> <p>improve air processing</p>
leaking between housing parts	<p>housing bolts loosened</p> <p>diaphragms attacked chemically</p> <p>diaphragms overstrained</p> <p>tension installation/pipework</p>	<p>disassemble the pump, clean sealing area, tighten housing bolts according to the torque values</p> <p>replace diaphragms</p> <p>replace diaphragms</p> <p>loosen, eliminate tension, use of a compensator</p>
muffler grey	driving air too humid, icing	improve quality of driving air
muffler black	soiled, oily air	improve quality of driving air, install sensitive filter in suction line
pump is connected to air but does not operate	<p>air control system blocked</p> <p>bulk particles/dirt</p> <p>chemical influence (O-rings swollen)</p> <p>valve closed in discharge line</p>	<p>clean/replace air control system</p> <p>clean pump, replace necessary parts, improve air quality</p> <p>check, replace damaged parts</p> <p>open valve</p>
liquid leaves the pump via the muffler	diaphragm rupture	replace diaphragms, clean pump

SPARE PART LIST MM-SERIES

<i>All parts in italics are not product wetted.</i>				MM 15	MM 25	MM 40
Item	Pc.	Description	Material	Part number	Part number	Part number
1	2	Side housing	1.4404/316L	25 15 010 23	25 25 010 23	25 40 010 23
2	2	Valve housing, discharge	1.4404/316L	25 15 139 23	25 25 139 23	25 40 139 23
3	2	Valve housing, suction	1.4404/316L	25 15 138 23	25 25 138 23	25 40 138 23
4	4	O-Ring, Valve housing (pump code STT)	FEP/FKM (FDA)	9 14 617 59	9 23 588 59	9 36 540 59
	4	O-Ring, Valve housing (pump code SEE)	EPDM (FDA)	9 14 617 73	9 23 588 73	9 36 540 73
5	1	Manifold, discharge	1.4404/316L	25 15 137 23	25 25 137 23	25 40 137 23
6	1	Manifold, suction	1.4404/316L	25 15 136 23	25 25 136 23	25 40 136 23
7	4	<i>Screw set manifold cpl.</i>	<i>1.4301</i>	<i>25 15 130 22</i>	<i>25 25 130 22</i>	<i>25 40 130 22</i>
8	2	Connection manifold TriClamp DIN 32676 (special code T)	<i>1.4404/316L</i>	<i>25 15 341 23</i>	<i>25 25 341 23</i>	<i>25 40 341 23</i>
		Connection manifold milk pipe DIN 11851 (code M)	<i>1.4404/316L</i>	<i>25 15 441 23</i>	<i>25 25 441 23</i>	<i>25 40 441 23</i>
		Connection manifold screwed aseptic connection DIN 11864-1 (code A1)	<i>1.4404/316L</i>	<i>25 15 541 23</i>	<i>25 25 541 23</i>	<i>25 40 541 23</i>
		Connection manifold aseptic flange connection DIN 11864-2 (code A2)	<i>1.4404/316L</i>	<i>25 15 641 23</i>	<i>25 25 641 23</i>	<i>25 40 641 23</i>
		Connection manifold aseptic clamp connection DIN 11864-3 (code A3)	<i>1.4404/316L</i>	<i>25 15 741 23</i>	<i>25 25 741 23</i>	<i>25 40 741 23</i>
		Connection manifold open butt welding end (code S)	<i>1.4404/316L</i>	<i>25 15 841 23</i>	<i>25 25 841 23</i>	<i>25 40 841 23</i>
9	2	O-Ring, Connection manifold (pump code STT)	FEP/FKM (FDA)	9 18 592 59	9 28 592 59	9 40 592 59
		O-Ring, Connection manifold (pump code SEE)	EPDM (FDA)	9 18 592 73	9 28 592 73	9 40 592 73
10	2	<i>Screw set suction/discharge port cpl.</i>	<i>1.4301</i>	<i>25 15 131 22</i>	<i>25 15 131 22</i>	<i>25 15 131 22</i>
11	4	<i>Mount flange</i>	<i>1.4404/316L</i>	<i>25 15 045 23</i>	<i>25 25 045 23</i>	<i>25 40 045 23</i>
12	4	<i>Valve stop</i>	<i>1.4404/316L</i>	<i>25 15 044 23</i>	<i>25 25 044 23</i>	<i>25 25 044 23</i>
13	8	O-Ring, Valve stop (pump code STT)	FEP/FKM (FDA)	9 23 588 59	9 39 100 59	9 60 100 59
		O-Ring, Valve stop (pump code SEE)	EPDM (FDA)	9 23 588 73	9 39 100 73	9 60 100 73
14	*	<i>Housing bolt, cpl.</i>	<i>1.4301</i>	<i>25 15 020 22</i>	<i>25 25 020 22</i>	<i>25 40 020 22</i>
15	4	<i>Shock absorber</i>	<i>EPDM white</i>	<i>1 15 022 78</i>	<i>1 15 022 78</i>	<i>1 40 022 78</i>
16	4	<i>Nut</i>	<i>1.4305</i>	<i>9 06 106 22</i>	<i>9 06 106 22</i>	<i>9 08 106 22</i>
17	1	<i>Shaft</i>	<i>1.4301</i>	<i>2 15 030 22</i>	<i>2 25 030 22</i>	<i>2 40 030 22</i>
18	2	<i>Set screw, shaft</i>	<i>1.4305</i>	<i>9 10 220 22</i>	<i>9 12 221 22</i>	<i>9 16 222 22</i>
19	2	Diaphragm (pump code STT)	PTFE/EPDM	1 15 031 67	1 25 031 67	1 40 031 67
	2	Diaphragm (pump code SEE)	EPDM	1 15 031 73	1 25 031 73	1 40 031 73
20	4	Valve ball (pump code STT)	PTFE	1 15 032 60	1 25 032 60	1 40 032 60
	4	Valve ball (pump code SEE)	EPDM	1 15 032 73	1 25 032 73	1 40 032 73
21	1	<i>Center block</i>	<i>PE-conductive</i>	<i>25 15 040 55</i>	<i>25 25 040 55</i>	<i>25 40 040 55</i>
22	2	<i>Frame</i>	<i>1.4404/316L</i>	<i>25 15 143 23</i>	<i>25 25 143 23</i>	<i>25 40 143 23</i>
23	2	<i>Shaft piston ring, cpl.</i>	<i>PTFE</i>	<i>1 15 041 64</i>	<i>1 25 041 64</i>	<i>1 40 041 64</i>
24	1	<i>Air inlet</i>	<i>PETP</i>	<i>1 15 047 84</i>	<i>1 15 047 84</i>	<i>1 40 047 84</i>
25	1	<i>Air filter</i>	<i>PE</i>	<i>1 15 043 51</i>	<i>1 15 043 51</i>	<i>1 40 043 51</i>
26	1	<i>Muffler</i>	<i>PE</i>	<i>1 15 244 51</i>	<i>1 15 244 51</i>	<i>1 40 244 51</i>
30	1	<i>PERSWING P® Air control system, cpl.</i>	<i>PETP</i>	<i>5 20 101 84</i>	<i>5 20 101 84</i>	<i>5 40 101 84</i>

* MM 15 / 25 = 6 Pcs. MM40 = 8 Pcs.

SPARE PART LIST MM-SERIES-USP

<i>Alle Teile in kursiver Schrift sind <u>nicht</u> produktberührt.</i>				MM 15 STT-...-USP	MM 25 STT-...-USP	MM 40 STT-...-USP
Item	Pc.	Description	Material	Part number	Part number	Part number
1	2	Side housing	1.4404	25 15 010 23	25 25 010 23	25 40 010 23
2	2	Valve housing, discharge	1.4404	25 15 139 23	25 25 139 23	25 40 139 23
3	2	Valve housing, suction	1.4404	25 15 138 23	25 25 138 23	25 40 138 23
4	4	O-Ring, Valve housing (pump code STT)	FEP/FKM (FDA)	9 14 617 59	9 23 588 59	9 36 540 59
5	1	Manifold, discharge	1.4404	25 15 137 23	25 25 137 23	25 40 137 23
6	1	Manifold, suction	1.4404	25 15 136 23	25 25 136 23	25 40 136 23
7	4	<i>Screw set manifold cpl.</i>	1.4301	25 15 130 22	25 25 130 22	25 40 130 22
8	2	Connection manifold TriClamp DIN 32676 (special code T)	1.4404	25 15 341 23	25 25 341 23	25 40 341 23
	2	Connection manifold milk pipe DIN 11851 (code M)	1.4404	25 15 441 23	25 25 441 23	25 40 441 23
	2	Connection manifold screwed aseptic connection DIN 11864-1 (code A1)	1.4404	25 15 541 23	25 25 541 23	25 40 541 23
	2	Connection manifold aseptic flange connection DIN 11864-2 (code A2)	1.4404	25 15 641 23	25 25 641 23	25 40 641 23
	2	Connection manifold aseptic clamp connection DIN 11864-3 (code A3)	1.4404	25 15 741 23	25 25 741 23	25 40 741 23
2	Connection manifold open butt welding end (code S)	1.4404	25 15 841 23	25 25 841 23	25 40 841 23	
9	2	O-Ring, Connection manifold (pump code STT)	FEP/FKM (FDA)	9 18 592 59	9 28 592 59	9 40 592 59
10	2	<i>Screw set suction/discharge port cpl.</i>	1.4301	25 15 131 22	25 15 131 22	25 15 131 22
11	4	<i>Mount flange</i>	1.4404	25 15 045 23	25 25 045 23	25 40 045 23
12	4	<i>Valve stop</i>	1.4404	25 15 044 23	25 25 044 23	25 25 044 23
13	8	O-Ring, Valve stop (pump code STT)	FEP/FKM (FDA)	9 23 588 59	9 39 100 59	9 60 100 59
14	*	<i>Housing bolt, cpl.</i>	1.4301	25 15 020 22	25 25 020 22	25 40 020 22
15	4	<i>Shock absorber</i>	EPDM weiß	1 15 022 78	1 15 022 78	1 40 022 78
16	4	<i>Nut</i>	1.4305	9 06 106 22	9 06 106 22	9 08 106 22
17	1	<i>Shaft</i>	1.4301	2 15 030 22	2 25 030 22	2 40 030 22
18	2	<i>Set screw, shaft</i>	1.4305	9 10 220 22	9 12 221 22	9 16 222 22
19	2	Diaphragm (pump code STT)	PTFE auf EPDM	1 15 031 67	1 25 031 67	1 40 031 67
20	4	Valve ball (pump code STT)	PTFE	1 15 032 60U	1 25 032 60U	1 40 032 60U
21	1	<i>Center block</i>	PE-leitfähig	25 15 040 55	25 25 040 55	25 40 040 55
22	2	<i>Frame</i>	1.4404	25 15 143 23	25 25 143 23	25 40 143 23
23	2	<i>Shaft piston ring, cpl.</i>	PTFE	1 15 041 64	1 25 041 64	1 40 041 64
24	1	<i>Air inlet</i>	PETP	1 15 047 84	1 15 047 84	1 40 047 84
25	1	<i>Air filter</i>	PE	1 15 043 51	1 15 043 51	1 40 043 51
26	1	<i>Muffler</i>	PE	1 15 244 51	1 15 244 51	1 40 244 51
30	1	<i>PERSWING P® Air control system, cpl.</i>	PETP	5 20 101 84	5 20 101 84	5 40 101 84

* MM 15 / 25 = 6 Pcs. MM40 = 8 Pcs.

EXPLODED VIEW

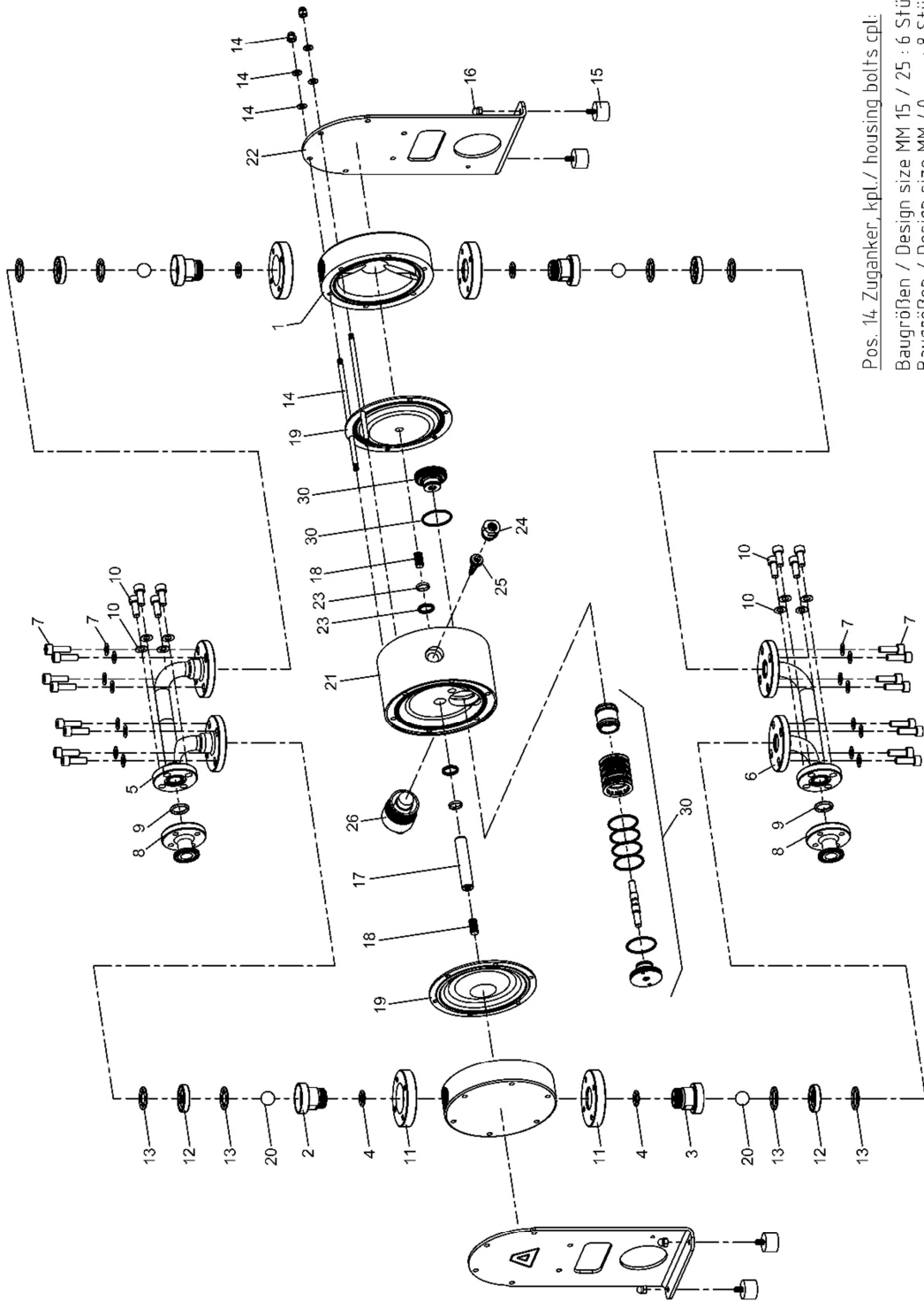

Pos. 14 Zuganker, kpl. / housing bolts cpl.
 Baugrößen / Design size MM 15 / 25 : 6 Stück / pcs.
 Baugrößen / Design size MM 40 : 8 Stück / pcs.

Dimensions

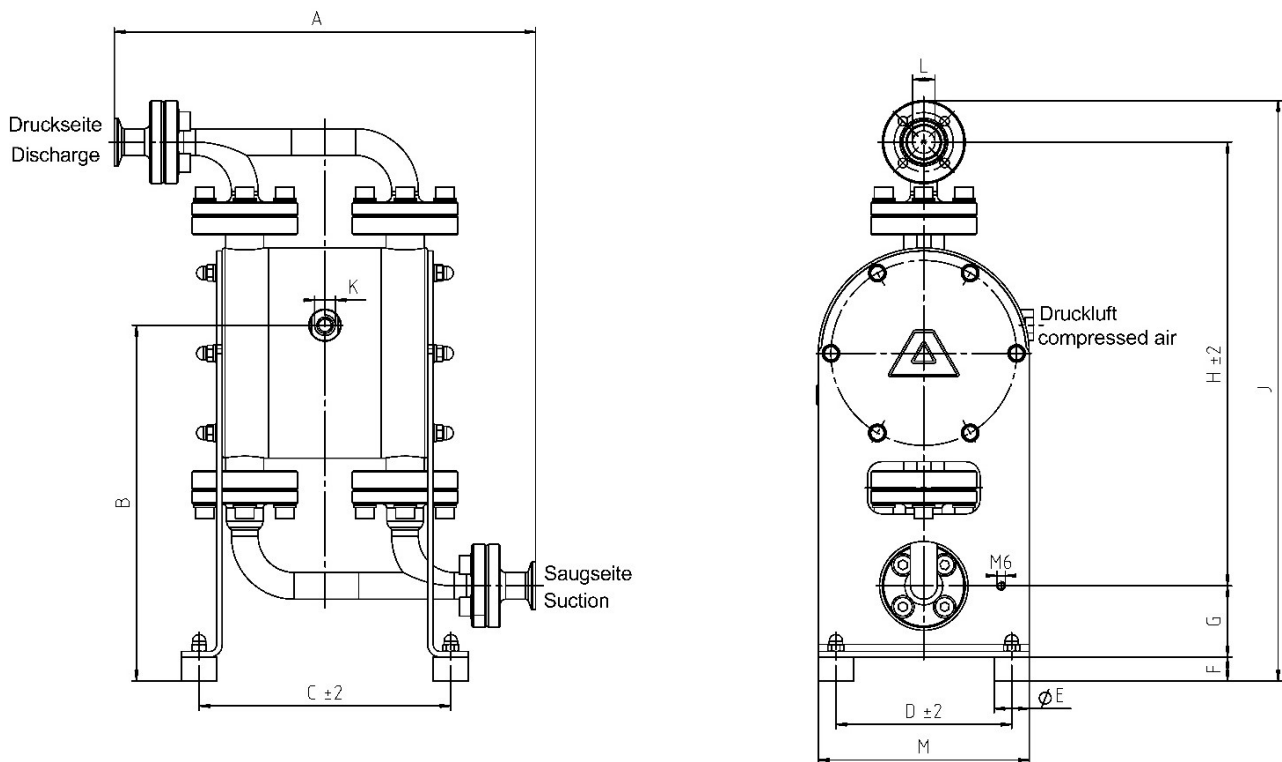

Metric Dimensions [mm]

mm	A	B	C	D	E	F	G	H	J	K	L	M
MM 15	299	253	179	125	Ø25	17	50,5	316	413	R 1/4"	DN 15	150
MM 25	358	333,5	226	175	Ø25	17	65	444	561	R 1/4"	DN 25	200
MM 40	435	403	330	228	Ø40	20	70	615	746	R 1/2"	DN 40	270

Imperial Dimensions [inch]

inch	A	B	C	D	E	F	G	H	J	K	L	M
MM 15	11.8	10.0	7.0	4.9	Ø1.0	0.7	2.0	12.4	16.3	¼"	½"	5.9
MM 25	14.1	13,1	8.9	6.9	Ø1.0	0.7	2.5	17.5	22	¼"	1"	7.9
MM 40	17.1	15,9	13.0	9.0	Ø1.6	0.8	2.7	24.2	29.4	½"	1 ½"	10.6

OPTIONAL EQUIPMENT

For special requirements ALMATEC pneumatic double diaphragm pump of the series Modular Metal can be furnished with several optional equipment's. The pump code informs, which of these are included in the pump (see page 4).

Stroke Counting (Optional equipment code C 2, C 3, C 4)

A sensor integrated in the center block [21] of the pump to monitor the movement of a diaphragm [19] without direct contact.

The stroke counting system is available in four variations:

- * C 2 Stroke sensor (Namur), also for explosion proof zone
- * C 3 Stroke counting system complete with sensor and stroke counter
- * C 4 Stroke counting system complete with sensor, stroke counter and controller for explosion proof zone

In case only the sensor is included (code C 2), it has to be connected to an existing controller. For applications an explosion-proof device is required for (code C 4) the intrinsically safe controller has to be installed between the sensor and the counter. The wiring diagram and technical data can be found on the electric units themselves.

For further details, please refer to the data delivered by the manufacturers of the components.

Spare parts stroke counting					MM 15	MM 25	MM 40
Code	Item	Pc.	Description	Material	Part number	Part number	Part number
C 2	21	1	Center block for sensor	PE-conductive	25 15 140 56	25 25 140 56	25 40 140 56
	50	1	Stroke sensor, Namur	several	1 00 072 99	1 00 072 99	1 00 072 99
C 3	-	1	as C 2, but additional: Clamp amplifier	several	1 00 171 99	1 00 171 99	1 00 171 99
	-	1	Stroke Counter	several	1 00 071 99	1 00 071 99	1 00 071 99
C 4	-	1	as C 2, but additional: Clamp amplifier	several	1 00 370 99	1 00 370 99	1 00 370 99
	-	1	Stroke Counter	several	1 00 071 99	1 00 071 99	1 00 071 99

Diaphragm Monitoring (Optional equipment code D 1, D 3)



A capacitive diaphragm sensor is mounted in the muffler [26] of the pump, which registers any liquid approaching the sensor, no matter whether the liquid is conductive or not. Hence, a fast reaction to a damage of a diaphragm becomes possible. However, it has to be considered, that the diaphragm monitoring possibly cannot prevent that liquid can leave the pump via the muffler. In case of humid surrounding air a false alert may occur despite operating the pump with dried compressed air.

The diaphragm monitoring system is available in two variations:

- * D 1 Diaphragm sensor (Namur), also for explosion proof area
- * D 3 Diaphragm monitoring system complete with sensor and controller



Subject to change without notice, 2021/07

PSG Germany GmbH
Hochstraße 150-152 · 47228 Duisburg · Germany
Telephone +49 (0) 20 65 / 89 2 05 - 0 · Telefax +49 (0) 20 65 / 89 2 05 - 40
<http://www.psgdover.com> · e-mail: psg-germany@psgdover.com